

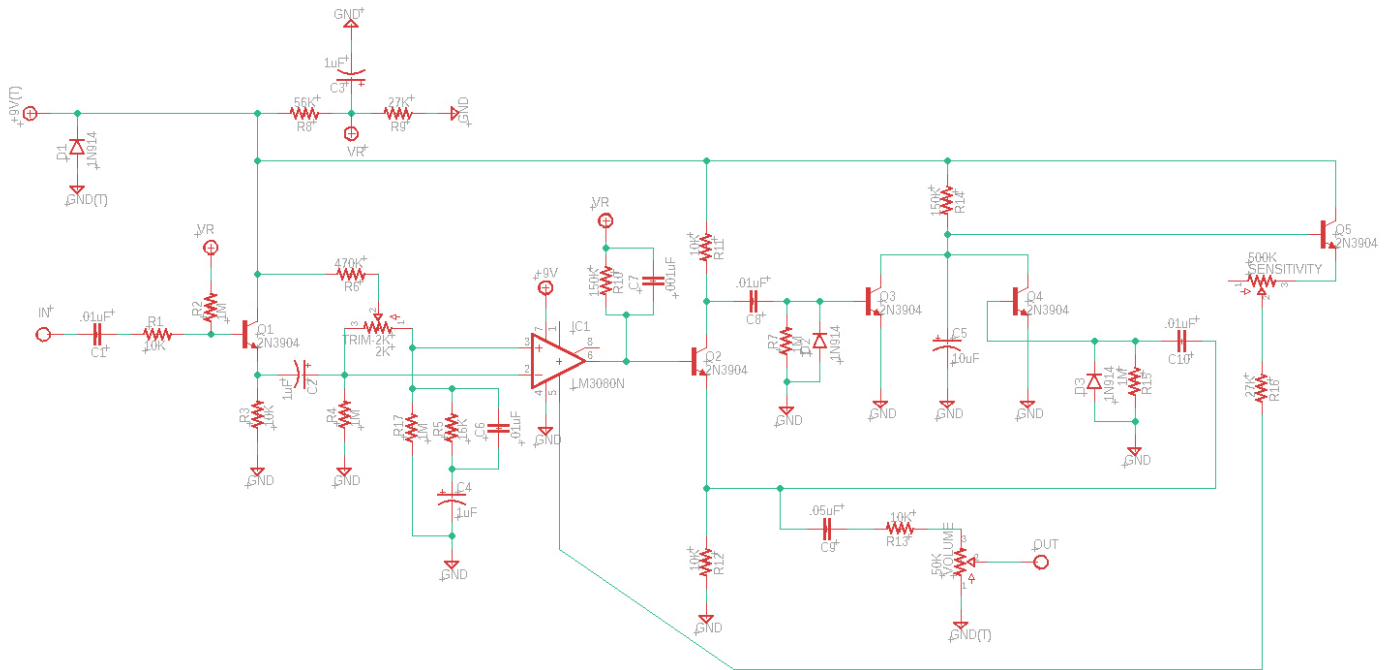

Ducky Comp (v2.3) Build Guide

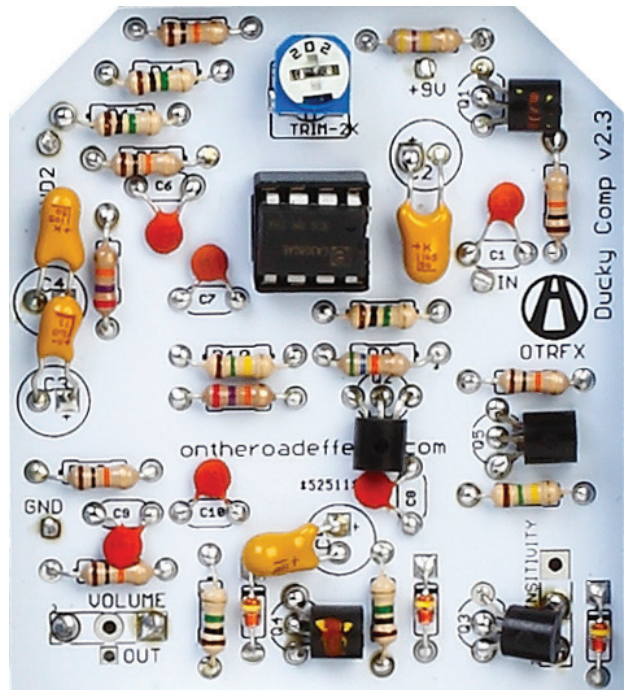
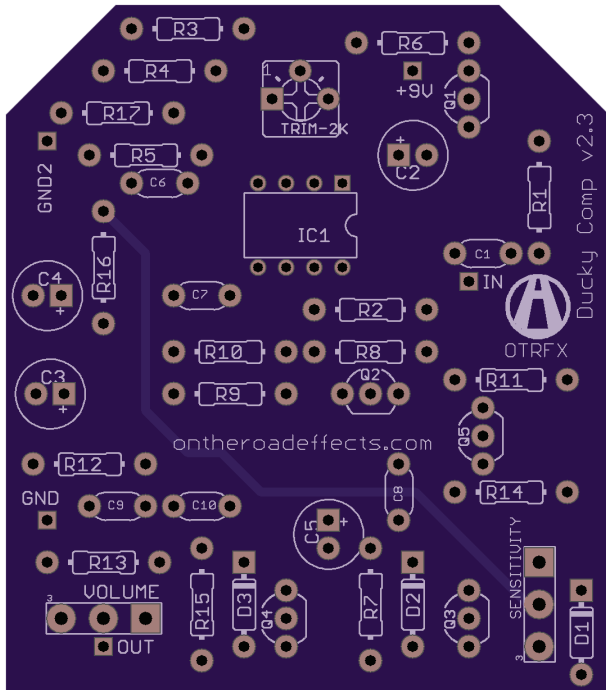

Ducky Comp (v2.3) Build Guide

The Ducky Comp is a near-faithful recreation of the exact PCB layout of the original MXR Dyna Comp pedal. All parts are designed to lay flat on the board, as was common in the era when this pedal was originally released. This allows you to build the pedal to vintage original specs and have your very own period-correct 1970's-era Dyna Comp.

Resistors

R1	10K
R2	1M
R3	10K
R4	1M
R5	16K
R6	470K
R7	1M
R8	56K
R9	27K
R10	150K
R11	10K
R12	10K
R13	10K
R14	150K
R15	1M
R16	27K
R17	1M

Diodes

D1	1N914
D2	1N914
D3	1N914

Capacitors

C1	.01uF	FILM / CERAMIC
C2	1uF	ELECTRO / TANTULUM
C3	1uF	ELECTRO / TANTULUM
C4	1uF	ELECTRO / TANTULUM
C5	10uF	ELECTRO / TANTULUM
C6	.01uF	FILM / CERAMIC
C7	.001uF	FILM / CERAMIC
C8	.01uF	FILM / CERAMIC
C9	.05uF	FILM / CERAMIC
C10	.01uF	FILM / CERAMIC

Transistors

Q1	*2N3904 / 2SC1849 / 2N5088
Q2	*2N3904 / 2SC1849 / 2N5088
Q3	*2N3904 / 2SC1849 / 2N5088
Q4	*2N3904 / 2SC1849 / 2N5088
Q5	*2N3904 / 2SC1849 / 2N5088

IC's

IC1	LM3080N (use IC socket!)
-----	--------------------------

Potentiometers

SENSITIVITY	B500K
VOLUME	A50K
TRIMPOT	2K

NOTES:

- All parts are designed to lay flat on the board, as per the original factory PCB. Transistors should be pushed over flat side down. Similarly, there is space on the board to push capacitors over as well.

- Polarized tantulum caps, which were used in the original, can be used in place of electrolytics (be careful not to overheat tantulums during soldering, as they are more sensitive to heat). For more vintage mojo, use ceramic caps in place of film.

* The most 'vintage spec' transistor would be the 2SC1849 (and in some cases MPS5172), but 2N3904, 2N5088 or 2N5089 may be substituted. Transistor pinouts on the PCB are as pictured here:



E B C

Ducky Comp (v2.3) Build Guide

MODS:

More / Less Low End:

C9 can be enlarged to 1uF for a fuller bottom end. Reduced values decrease the bottom rolloff frequency.

More Treble:

C7 can be lowered (or removed) to increase treble response. Try 100pF to 560pF, or remove.

Less Bass:

R5 creates a low pass filter. If less bass is desired, experiment with values between 10K and 27K.

Attack Time Mod:

You can replace **R14** with an SPDT on-on switch to change the attack time by using the modification diagrammed below:

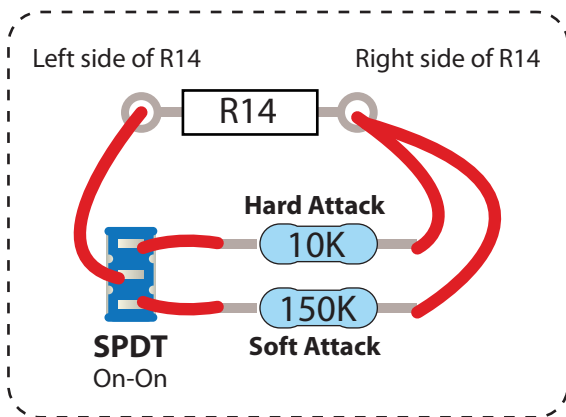

RESOURCES:

Parts Ordering:

Tayda Electronics
Mouser
Love My Switches

Website:

taydaelectronics.com
mouser.com
lovemyswitches.com

Specialties:

resistors, capacitors, diodes, sockets, LEDs, pots, knobs
resistors, capacitors, IC's
switches, knobs, enclosures, pre-wired LEDs

GENERAL INSTRUCTION STEPS:

Important: do the assembly in the following order to avoid unnecessary hardship!



1. Install/solder all resistors & diodes that lay flat on the PCB.
2. Install/solder any sockets (for IC's, diodes, resistors... anywhere you might want to change a part, value or type).
3. Install/solder any DIP switches (if any).
4. Install/solder all capacitors & transistors.
5. Wire all pots, jacks and switches with hookup wire. (**Important:** Use pot dust caps or some other non-conductive material to keep back of pots from touching the back of the pcb).
6. Wire LED according to the wiring diagram, and be sure to use a current limiting resistor in the range of about 2K-4K (2K will be brighter, 4K will be dimmer).

TIPS:

- Check to make sure your wiring is complete before firing up the pedal for the first time, especially the 9v & ground wiring.
- Snip your component leads short after soldering. Your solder joints should look like shiny little Hershey's Kisses when finished.
- Socket anything you might want to change, or anything that would be very difficult to remove if faulty (IC's/transistors).



PEDAL BUILDER'S VECTOR PACK

Plan, design, test-fit, & print your DIY pedals with ease!
Visit ontheroadeffects.com

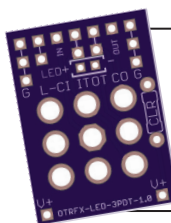

HATE WIRING STOMPSWITCHES?

Stock up on our handy 3PDT wiring boards!
Visit ontheroadeffects.com

Ducky Comp (v2.3) Build Guide

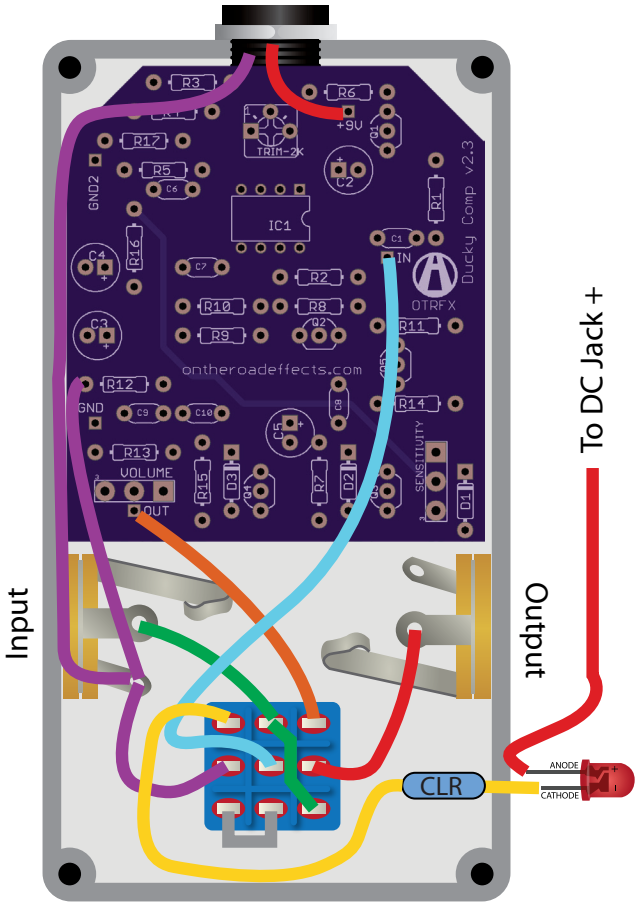
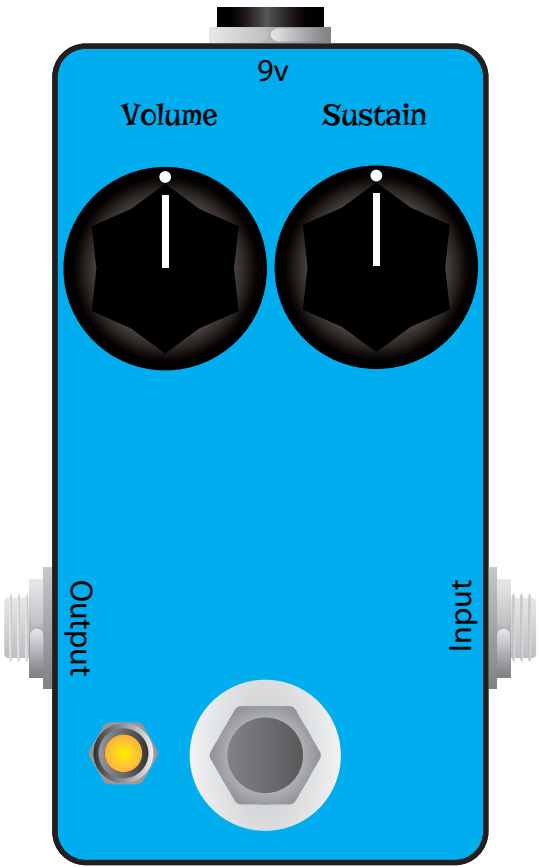

True Bypass Wiring

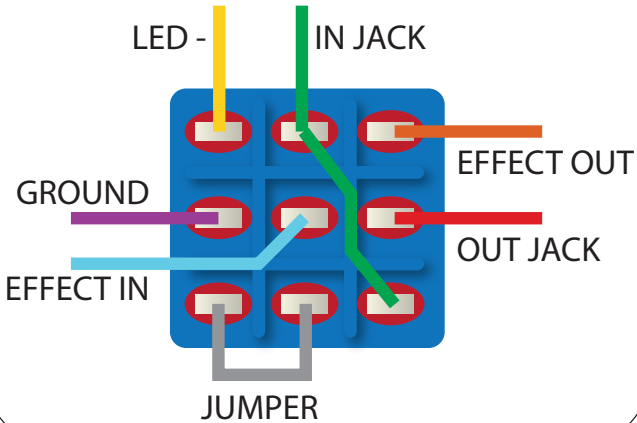

Pots/LED Drill Holes

